

**CENTRAL MACHINERY**

®

# 13" PLANER WITH DUST COLLECTOR

**Model 98524**

## SET UP AND OPERATING INSTRUCTIONS



Distributed exclusively by Harbor Freight Tools®.

3491 Mission Oaks Blvd., Camarillo, CA 93011

Visit our website at: <http://www.harborfreight.com>



**Read this material before using this product.  
Failure to do so can result in serious injury.  
SAVE THIS MANUAL.**

Copyright© 2008 by Harbor Freight Tools®. All rights reserved. No portion of this manual or any artwork contained herein may be reproduced in any shape or form without the express written consent of Harbor Freight Tools. Diagrams within this manual may not be drawn proportionally. Due to continuing improvements, actual product may differ slightly from the product described herein. Tools required for assembly and service may not be included.

**For technical questions or replacement parts, please call 1-800-444-3353.**

---

## SAVE THIS MANUAL

---

Keep this manual for the safety warnings and precautions, assembly, operating, inspection, maintenance and cleaning procedures. Write the product's serial number in the back of the manual near the assembly diagram (or month and year of purchase if product has no number). Keep this manual and the receipt in a safe and dry place for future reference.

---

## IMPORTANT SAFETY INFORMATION

---

In this manual, on the labeling, and all other information provided with this product:



This is the safety alert symbol. It is used to alert you to potential personal injury hazards. Obey all safety messages that follow this symbol to avoid possible injury or death.

### **DANGER**

**DANGER** indicates a hazardous situation which, if not avoided, will result in death or serious injury.

### **WARNING**

**WARNING** indicates a hazardous situation which, if not avoided, could result in death or serious injury.

### **CAUTION**

**CAUTION**, used with the safety alert symbol, indicates a hazardous situation which, if not avoided, could result in minor or moderate injury.

### **NOTICE**

**NOTICE** is used to address practices not related to personal injury.

### **CAUTION**

**CAUTION**, without the safety alert symbol, is used to address practices not related to personal injury.

---

## General Power Tool Safety Warnings



**WARNING** Read all safety warnings and instructions. Failure to follow the warnings and instructions may result in electric shock, fire and/or serious injury. Save all warnings and instructions for future reference. The term "power tool" in the warnings refers to your mains-operated (corded) power tool.

1. **Work area safety**
  - a. **Keep work area clean and well lit.** Cluttered or dark areas invite accidents.
  - b. **Do not operate power tools in explosive atmospheres, such as in the presence of flammable liquids, gases or dust.** Power tools create sparks which may ignite the dust or fumes.
  - c. **Keep children and bystanders away while operating a power tool.** Distractions can cause you to lose control.
2. **Electrical safety**
  - a. **Power tool plugs must match the outlet. Never modify the plug in any way. Do not use any adapter plugs with grounded power tools.**

*Unmodified plugs and matching outlets will reduce risk of electric shock.*

- b. Avoid body contact with grounded surfaces such as pipes, radiators, ranges and refrigerators.** *There is an increased risk of electric shock if your body is grounded.*
  - c. Do not expose power tools to rain or wet conditions.** *Water entering a power tool will increase the risk of electric shock.*
  - d. Do not abuse the cord. Never use the cord for carrying, pulling or unplugging the power tool. Keep cord away from heat, oil, sharp edges or moving parts.** *Damaged or entangled cords increase the risk of electric shock.*
  - e. When operating a power tool outdoors, use an extension cord suitable for outdoor use.** *Use of a cord suitable for outdoor use reduces the risk of electric shock.*
  - f. If operating a power tool in a damp location is unavoidable, use a Ground Fault Circuit Interrupter (GFCI) protected supply.** *Use of a GFCI reduces the risk of electric shock.*
- 3. Personal safety**
- a. Stay alert, watch what you are doing and use common sense when operating a power tool. Do not use a power tool while you are tired or under the influence of drugs, alcohol or medication.** *A moment of inattention while operating power tools may result in serious personal injury.*
  - b. Use personal protective equipment. Always wear ANSI-approved eye protection.** *Safety equipment such as dust mask, non-skid safety shoes, hard hat, or hearing protection used for appropriate conditions will reduce personal injuries.*
  - c. Prevent unintentional starting. Ensure the switch is in the off-position before connecting to power source and/or battery pack, picking up or carrying the tool. Carrying power tools with your finger on the switch or energizing power tools that have the switch on invites accidents.**
  - d. Remove any adjusting key or wrench before turning the power tool on.** *A wrench or a key left attached to a rotating part of the power tool may result in personal injury.*
  - e. Do not overreach. Keep proper footing and balance at all times.** *This enables better control of the power tool in unexpected situations.*
  - f. Dress properly. Do not wear loose clothing or jewelry. Keep your hair, clothing and gloves away from moving parts.** *Loose clothes, jewelry or long hair can be caught in moving parts.*
  - g. If devices are provided for the connection of dust extraction and collection facilities, ensure these are connected and properly used.** *Use of these devices can reduce dust-related hazards.*
  - h. Only use safety equipment that has been approved by an appropriate standards agency.** *Unapproved safety equipment may not provide adequate protection. Eye protection must be ANSI-approved and breathing protection must be NIOSH-approved for the specific hazards in the work area.*

4. **Power tool use and care**
  - a. **Do not force the power tool. Use the correct power tool for your application.** *The correct power tool will do the job better and safer at the rate for which it was designed.*
  - b. **Do not use the power tool if the switch does not turn it on and off.** *Any power tool that cannot be controlled with the switch is dangerous and must be repaired.*
  - c. **Disconnect the plug from the power source and/or the battery pack from the power tool before making any adjustments, changing accessories, or storing power tools.** *Such preventive safety measures reduce the risk of starting the power tool accidentally.*
  - d. **Store idle power tools out of the reach of children and do not allow persons unfamiliar with the power tool or these instructions to operate the power tool.** *Power tools are dangerous in the hands of untrained users.*
  - e. **Maintain power tools. Check for misalignment or binding of moving parts, breakage of parts and any other condition that may affect the power tool's operation. If damaged, have the power tool repaired before use.** *Many accidents are caused by poorly maintained power tools.*
  - f. **Keep cutting tools sharp and clean.** *Properly maintained cutting tools with sharp cutting edges are less likely to bind and are easier to control.*
  - g. **Use the power tool, accessories and tool bits etc. in accordance with these instructions, taking into**

**account the working conditions and the work to be performed.** *Use of the power tool for operations different from those intended could result in a hazardous situation.*

5. **Service**
  - a. **Have your power tool serviced by a qualified repair person using only identical replacement parts.** *This will ensure that the safety of the power tool is maintained.*

### Specific Safety Warnings

1. **Always wear ANSI-approved safety impact eye goggles and heavy-duty work gloves when using Planer.** *Using personal safety devices reduce the risk for injury. Safety impact eye goggles and heavy work gloves are available from Harbor Freight Tools. Dust mask, non skid safety shoes, hard hat, or hearing protection must be used for appropriate conditions.*
2. **Use a platform, or other practical way, to support a long workpiece as it enters the Planer.** *Holding the work by hand or against your body is unstable and may lead to loss of control.*
3. **Avoid unintentional starting.** *Make sure you are prepared to begin work before turning on the Planer.*
4. **Do not force the Planer.** *This tool will do the work better and safer at the speed and capacity for which it was designed.*
5. **Always unplug the Planer from its electrical outlet before changing blades or performing any inspection, maintenance, or cleaning procedures.**

6. **Never leave the Planer unattended while running.** *Turn power off if you have to leave the Planer.*
7. **Turn off Planer when jammed.**
8. **Before each use, check all nuts, bolts, and screws for tightness.**
9. **Keep extension cord off the ground and away from water.**
10. **Install this product on a proper surface.** *Locate on a flat, level, and solid surface that is capable of supporting the weight of the Planer and the stock being planed.*
11. **Maintain labels and nameplates on the tool.** *These carry important safety information. If unreadable or missing, contact Harbor Freight Tools for a replacement.*
12. **This product is not a toy.** *Keep it out of reach of children.*
13. **People with pacemakers should consult their physician(s) before use.** *Electromagnetic fields in close proximity to heart pacemaker could cause pacemaker interference or pacemaker failure. In addition, people with pacemakers should:*
  - *Avoid operating alone.*
  - *Do not use with power switch locked on.*
  - *Properly maintain and inspect to avoid electrical shock.*
  - *Any power cord must be properly grounded. Ground Fault Circuit Interrupter (GFCI) should also be implemented – it prevents sustained electrical shock.*
14. **Some dust created by power sanding, sawing, grinding, drilling, and other construction activities,**

**contains chemicals known [to the State of California] to cause cancer, birth defects or other reproductive harm.** *Some examples of these chemicals are:*

- *Lead from lead-based paints*
- *Crystalline silica from bricks and cement or other masonry products*
- *Arsenic and chromium from chemically treated lumber*

*Your risk from these exposures varies, depending on how often you do this type of work. To reduce your exposure to these chemicals: work in a well ventilated area, and work with approved safety equipment, such as those dust masks that are specially designed to filter out microscopic particles. (California Health & Safety Code § 25249.5, et seq.)*

15. **The warnings, precautions, and instructions discussed in this instruction manual cannot cover all possible conditions and situations that may occur.** *It must be understood by the operator that common sense and caution are factors which cannot be built into this product, but must be supplied by the operator.*



**SAVE THESE INSTRUCTIONS.**

---

## GROUNDING

---

### **⚠️ WARNING** TO PREVENT ELECTRIC SHOCK



#### AND DEATH FROM INCORRECT GROUNDING WIRE CONNECTION:

Check with a qualified electrician if you are in doubt as to whether the outlet is properly grounded. Do not modify the power cord plug provided with the tool. Never remove the grounding prong from the plug. Do not use the tool if the power cord or plug is damaged. If damaged, have it repaired by a service facility before use. If the plug will not fit the outlet, have a proper outlet installed by a qualified electrician.

---

### Grounded Tools: Tools with Three Prong Plugs

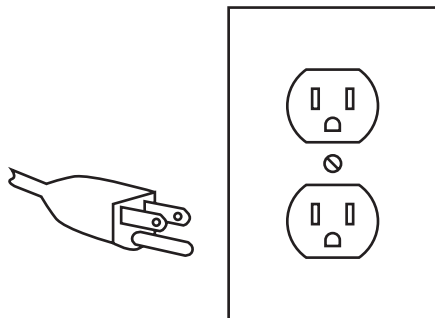

**3-Prong Plug and Outlet**

1. Tools marked with “Grounding Required” have a three wire cord and three prong grounding plug. The plug must be connected to a properly grounded outlet. If the tool should electrically malfunction or break down, grounding provides a low resistance path to carry electricity away from the user, reducing the risk

of electric shock. (See **3-Prong Plug and Outlet.**)

2. The grounding prong in the plug is connected through the green wire inside the cord to the grounding system in the tool. The green wire in the cord must be the only wire connected to the tool’s grounding system and must never be attached to an electrically “live” terminal. (See **3-Prong Plug and Outlet.**)
3. The tool must be plugged into an appropriate outlet, properly installed and grounded in accordance with all codes and ordinances. The plug and outlet should look like those in the preceding illustration. (See **3-Prong Plug and Outlet.**)

---

### Double Insulated Tools: Tools with Two Prong Plugs

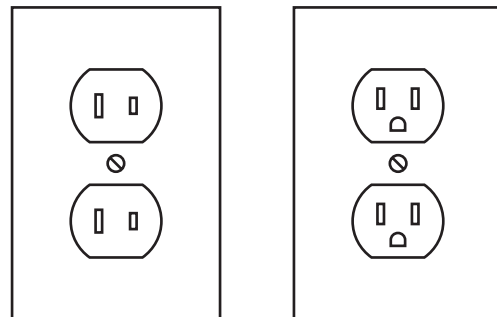

**Outlets for 2-Prong Plug**

1. Tools marked “Double Insulated” do not require grounding. They have a special double insulation system which satisfies OSHA requirements and complies with the applicable standards of Underwriters Laboratories, Inc., the Canadian Standard Association, and the National Electrical Code. (See **Outlets for 2-Prong Plug.**)

- Double insulated tools may be used in either of the 120 volt outlets shown in the preceding illustration. **(See Outlets for 2-Prong Plug.)**

### Extension Cords

- Grounded** tools require a three wire extension cord. **Double Insulated** tools can use either a two or three wire extension cord.
- As the distance from the supply outlet increases, you must use a heavier gauge extension cord. Using extension cords with inadequately sized wire causes a serious drop in voltage, resulting in loss of power and possible tool damage. **(See Table A.)**
- The smaller the gauge number of the wire, the greater the capacity of the cord. For example, a 14 gauge cord can carry a higher current than a 16 gauge cord. **(See Table A.)**
- When using more than one extension cord to make up the total length, make sure each cord contains at least the minimum wire size required. **(See Table A.)**
- If you are using one extension cord for more than one tool, add the nameplate amperes and use the sum to determine the required minimum cord size. **(See Table A.)**
- If you are using an extension cord outdoors, make sure it is marked with the suffix "W-A" ("W" in Canada) to indicate it is acceptable for outdoor use.
- Make sure the extension cord is properly wired and in good electrical con-





dition. Always replace a damaged extension cord or have it repaired by a qualified electrician before using it.

- Protect the extension cords from sharp objects, excessive heat, and damp or wet areas.

<b>RECOMMENDED MINIMUM WIRE GAUGE FOR EXTENSION CORDS* (120/240 VOLT)</b>					
<b>NAMEPLATE AMPERES (at full load)</b>	<b>EXTENSION CORD LENGTH</b>				
	<b>25'</b>	<b>50'</b>	<b>75'</b>	<b>100'</b>	<b>150'</b>
0 – 2.0	18	18	18	18	16
2.1 – 3.4	18	18	18	16	14
3.5 – 5.0	18	18	16	14	12
5.1 – 7.0	18	16	14	12	12
7.1 – 12.0	18	14	12	10	-
12.1 – 16.0	14	12	10	-	-
16.1 – 20.0	12	10	-	-	-

**TABLE A** \* Based on limiting the line voltage drop to five volts at 150% of the rated amperes.

### Symbology

	Double Insulated
	Canadian Standards Association
	Underwriters Laboratories, Inc.
	Volts Alternating Current
	Amperes
n <sub>0</sub> xxxx/min.	No Load Revolutions per Minute (RPM)

## SPECIFICATIONS

Electrical Requirements	120 V~ / 60 Hz / 15 A
Motor (Cutter head) Speed	8,000 RPM, 16,000 cuts per minute
Maximum Cutting Depth	3/32"
Stock Capacity	13" W x 6" H
Cutting Blades	Two 13-1/8" L
Feed Speed	23 Feet per Minute
Dust Port Opening	2-3/16" I.D.
Included Accessories	1 Hex Wrench (4mm) 2 Magnets 1 Dust Bag

## UNPACKING

When unpacking, check to make sure that the item is intact and undamaged. If any parts are missing or broken, please call Harbor Freight Tools at the number shown on the cover of this manual as soon as possible.

## INSTRUCTIONS FOR PUTTING INTO USE



Read the **ENTIRE IMPORTANT SAFETY INFORMATION** section at the beginning of this manual including all text under subheadings therein before set up or use of this product.



### TO PREVENT SERIOUS INJURY

#### FROM ACCIDENTAL OPERATION:

Turn the Power Switch of the tool to its "OFF" position and unplug the tool from its electrical outlet before assembling or making any adjustments to the tool.

**Note:** For additional information regarding the parts listed in the following pages, refer to the Assembly Diagram near the end of this manual.

## Assembly

1. Select an area with enough room to fit the chosen dust collection system. Select a workbench to mount the Planer. Place the Planer on a workbench able to support the weight of the Planer and the wood stock being planed. The orientation of the Planer should enable the easy entry and exit of long pieces of wood stock.
2. Using a pencil, mark through the mounting holes of the Planer, onto the workbench. Slide the Planer aside and drill four 3/8 inch mounting holes into the workbench.
3. Slide the Planer back over the mounting holes in the workbench, and secure the Planer to the workbench with bolts, washers, spring washers and nuts (not included). Securely tighten.

### ⚠ WARNING

Before drilling, verify that there are no utility wires or other obstructions under the workbench.

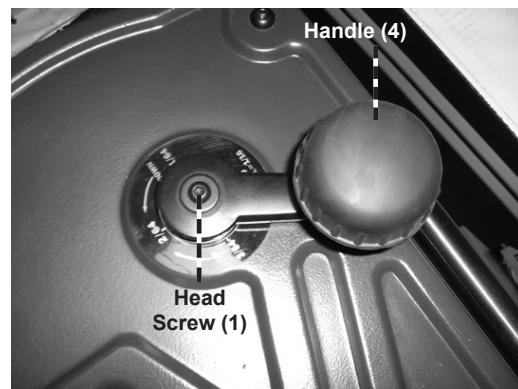



4. Mount the Elevating Handle (4) on top of the unit on the right or left side with Flat Washer (2) and Head Screw (1), as shown above. Place the Cap (9) on the other side.
5. The Filter Bag (27.6) of the dust collection system has an open bottom. The open bottom should be connected to a thirty gallon plastic bag or garbage can (neither included) using the Connector (27.8) and fasten with the Pin (27.7).

3. There must not be hazardous objects, such as utility lines or foreign objects, nearby that will present a hazard while working.

## **OPERATING INSTRUCTIONS**



Read the **ENTIRE IMPORTANT SAFETY INFORMATION** section at the beginning of this manual including all text under subheadings therein before set up or use of this product.

### **Tool Set Up**



**TO PREVENT SERIOUS INJURY**

**FROM ACCIDENTAL OPERATION:**

Turn the Power Switch of the tool to its “OFF” position and unplug the tool from its electrical outlet before performing any inspection, maintenance, or cleaning procedures.

### **Work Piece and Work Area Set Up**

1. Designate a work area that is clean and well-lit. The work area must not allow access by children or pets to prevent injury and distraction.
2. Route the power cord along a safe route to reach the work area without

creating a tripping hazard or exposing the power cord to possible damage. The power cord must reach the work area with enough extra length to allow free movement while working.

## **General Operating Instructions**

1. Lower the Table Support (221) and the Extension Table (222).
2. The Adjustment Knob on top of the Planer is used to adjust the depth of cut. Recommended depth of cut is as follows:
  - Wood up to 6” wide: 3/32”
  - Wood over 6” wide: 1/16”
  - The depth of the cut is read on the meter above the cutting area on the front of the Planer.
3. The pre-set Thickness Knob can be adjusted to set to the maximum thickness desired; 1/8”, 1/4”, 1/2”, 3/4”, 1” or 1-1/4”. See below.



4. The Planer can be locked to ensure an even cut by pulling the handle

of the Lock Lever (49) down. See below.

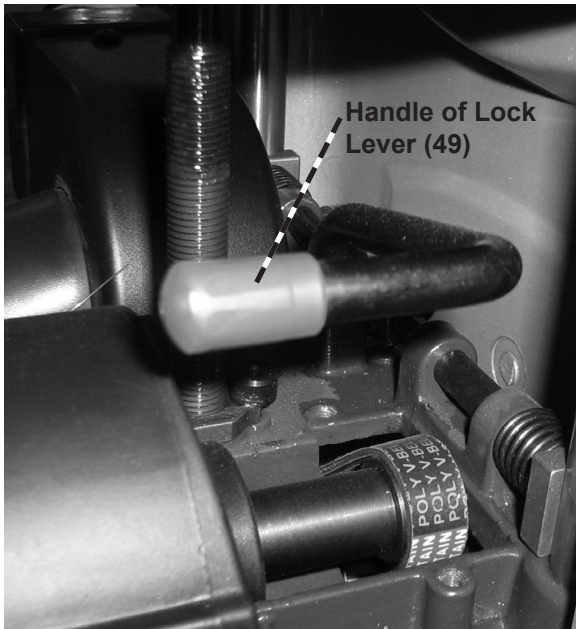

- The Handle (75) can be used to vary the depth or shallowness of cut beyond the pre-set Thickness Knob.

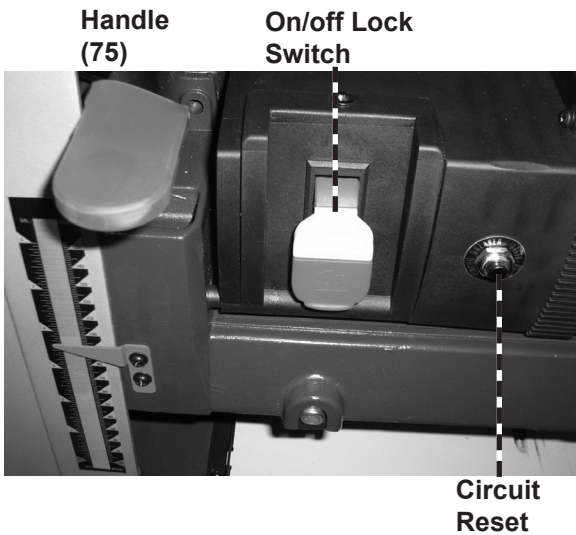

- Plug the Planer into a grounded, 120V electrical outlet.

**Note:** Do not stand behind the end of the board during planing. Plane dry, unwarped, clean boards only. Avoid planing boards that have knots; loose knots can jam the machine or

become a projectile. Do not plane boards that have foreign objects (nails, staples, etc.) in them.

- Do not plane material:
  - shorter than 15",
  - narrower than 3/4",
  - wider than 13",
  - or thinner than 1/8"
- Push the On/Off Lock switch down to turn the Planer on. Allow the planer to come up to full speed before beginning a job.
- The planer has a maximum depth cut of 3/32" per pass. The Planer will operate best when the depth of cut is less than 1/16". It is recommended to make a series of shallow cuts rather than a single deep cut.

**Note:** Always keep the boards being planed level. Support long boards at both ends.

- Plane along the grain of the wood.
- Plane alternating sides of the board until the desired thickness is achieved.
- When planing multiple boards to the same thickness place the ends so they are touching (butting) for best results.
- An assistant can return the boards to the operator using the Rollers (13) on top of the Planer.
- If the Planer turns off unexpectedly during operation; turn the Planer off and unplug it from the electrical outlet. Refer to the "Troubleshooting Section" of this manual for possible reasons. If the Circuit Breaker has

tripped, remove any materials from the Planer and push the Circuit Reset button.

15. To prevent accidents, turn off the tool and disconnect its power supply after use. Clean, then store the tool indoors out of children's reach.

---

## MAINTENANCE AND SERVICING

---



Procedures not specifically explained in this manual must be performed only by a qualified technician.

### **WARNING**

#### **TO PREVENT SERIOUS INJURY**

##### **FROM ACCIDENTAL OPERATION:**

Turn the Power Switch of the tool to its “OFF” position and unplug the tool from its electrical outlet before performing any inspection, maintenance, or cleaning procedures.

##### **TO PREVENT SERIOUS INJURY FROM TOOL FAILURE:**

Do not use damaged equipment. If abnormal noise or vibration occurs, have the problem corrected before further use.

---

### **Cleaning, Maintenance, and Lubrication**

1. **BEFORE EACH USE**, inspect the general condition of the tool. Check for loose screws, misalignment or binding of moving parts, cracked or broken parts, damaged electrical wiring, and any other condition that may affect its safe operation.
2. **AFTER USE**, clean external surfaces of the tool with clean cloth.
3. **PERIODICALLY**, blow the interior of the Planer out with compressed air

and lubricate moving parts with white lithium grease.

4. **CARBON BRUSH MAINTENANCE.** The carbon brushes may require maintenance when the motor performance of the tool decreases or stops working completely. To maintain the brushes:
  - a. Remove the brush caps on the front and back of the motor housing.
  - b. Remove the carbon brushes from the housing. **Keep track of which orientation the old carbon brushes were in to prevent needless wear if they will be reinstalled.**
  - c. If either carbon brush is worn down by more than 1/2, replace **both** carbon brushes.
  - d. To clean old carbon brushes before reusing them, rub the contact areas with a pencil eraser.
  - e. Reinsert the old carbon brushes in the same orientation to reduce wear.
  - f. When installing the carbon brushes, make sure the carbon portions of the carbon brushes contact the motor armature, and that the springs face away from the motor. Also, make sure the springs operate freely.
  - g. Replace the brush caps. Do not overtighten.

**Note:** New carbon brushes tend to spark when first used until they wear and conform to the motor’s armature.

5. **BLADE MAINTENANCE.** When cutting ability deteriorates or the planed surface starts to get uneven or rough, the blades will have to be replaced.

6. Use the included Hex Wrench to remove both Hex Bolts on the back of the blade case.

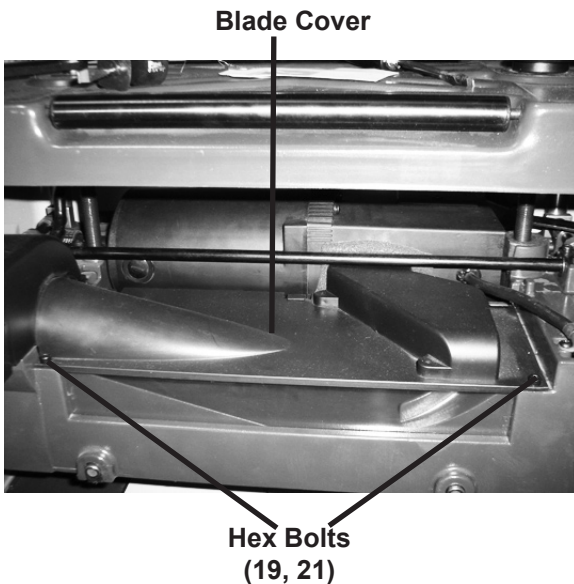

7. Remove the Blade Cover.
8. Wearing work gloves, rotate the cutter head until the latch engages.
9. Remove the six bolts (172) from the Cutter Head (168) and use the magnets to remove it.
10. Use the magnets to remove the Blade (171) from the pins that hold it in place.
11. Using the magnets, put a new blade onto the pins.
12. Replace the Cutter Head and secure it.
13. Push down on the latch to release the cutter head.
14. Rotate the cutter head until it latches in place and replace the other blade as instructed above.

**Note:** Always replace both blades at the same time.

15. Replace the cover. Secure all hardware.
16. **ADJUST ROLLER CASE LEVEL.** If the Roller Case (151) is not parallel to the base (212), the planer will produce cuts of uneven depth.
17. Use a test piece to measure the height of the taper.
18. Turn the Planer off and disconnect it from the power supply.
19. Fold both Extension Tables up and lay the planer on its back.
20. Loosen the two Head Screws (226, 232). Loosen the Chain (231) by sliding the Idler Bracket (224).
21. Rotate the Elevation Screws (211) to correct the orientation of the Roller Case to Base. Each turn of the screw will move the Roller Case by 1/16".
22. **REPLACING THE V-BELT.** Remove the Elevating Handle (4).
23. Remove the four Head Screws (15) from the Upper Cover (10). Remove the Upper Cover.
24. Remove the right side cover.
25. Remove the V-Belts (61, 186) from the Pulleys (188 & 189, 60 & 184) and replace with new belts. Always change both belts at the same time.
26. Reassemble the Planer.
27. **⚠WARNING! If the supply cord of this power tool is damaged, it must be replaced only by a qualified service technician.**

## Troubleshooting

<b>Problem</b>	<b>Possible Causes</b>	<b>Likely Solutions</b>
Tool will not start	<ol style="list-style-type: none"> <li>1. No power at outlet.</li> <li>2. Cord not connected.</li> </ol>	<ol style="list-style-type: none"> <li>1. Check power at outlet.</li> <li>2. Check that cord is plugged in.</li> </ol>
Gouging at ends of board (snipe)	<ol style="list-style-type: none"> <li>1. Dull Blades.</li> <li>2. Too little support of long boards.</li> <li>3. Uneven force on cutter head.</li> <li>4. Roller case not level with base.</li> <li>5. Lumber not butted properly.</li> </ol>	<ol style="list-style-type: none"> <li>1. Replace blades.</li> <li>2. Provide better support for long blades.</li> <li>3. Adjust board when it is in contact with only one feed roller.</li> <li>4. Adjust roller case.</li> <li>5. Butt each end of stock together evenly.</li> </ol>
Grain is ragged	<ol style="list-style-type: none"> <li>1. Wood has a high moisture content.</li> </ol>	<ol style="list-style-type: none"> <li>1. Dry the wood.</li> </ol>
Torn grain	<ol style="list-style-type: none"> <li>1. Cut is too heavy.</li> <li>2. Blades cutting against grain.</li> <li>3. Dull blades.</li> </ol>	<ol style="list-style-type: none"> <li>1. Reduce depth of cut.</li> <li>2. Cut boards along grain.</li> <li>3. Replace blades.</li> </ol>
Rough, raised grain	<ol style="list-style-type: none"> <li>1. Dull blades.</li> <li>2. Cut is too heavy.</li> <li>3. Moisture content is too high.</li> </ol>	<ol style="list-style-type: none"> <li>1. Replace blades.</li> <li>2. Reduce depth of cut.</li> <li>3. Dry the wood.</li> </ol>
Uneven side-to-side depth of cut	<ol style="list-style-type: none"> <li>1. Roller case not level with planer base.</li> </ol>	<ol style="list-style-type: none"> <li>1. Adjust so that roller case is level.</li> </ol>
Roller case adjustment difficult	<ol style="list-style-type: none"> <li>1. Sprockets or chain dirty.</li> <li>2. Elevation screws or columns dirty.</li> <li>3. Elevation screws worn.</li> <li>4. Friction between roller case and covers.</li> <li>5. Roller case not parallel.</li> <li>6. Roller case lock engaged.</li> </ol>	<ol style="list-style-type: none"> <li>1. Clean and lubricate sprockets and chain.</li> <li>2. Clean and lubricate elevation screws and columns.</li> <li>3. Replace elevation screws.</li> <li>4. Clean and lubricate roller case and cover.</li> <li>5. Adjust roller case.</li> <li>6. Release roller case lock.</li> </ol>
Board feeds in, but will not move through.	<ol style="list-style-type: none"> <li>1. Out feed rollers are clogged.</li> <li>2. Too much pressure on cutter head from long board.</li> </ol>	<ol style="list-style-type: none"> <li>1. Clean Planer.</li> <li>2. Use supports to hold workpiece up.</li> </ol>
Board thickness does not match depth of cut scale.	<ol style="list-style-type: none"> <li>1. Indicator not set correctly.</li> </ol>	<ol style="list-style-type: none"> <li>1. Have indicator repaired by a qualified technician.</li> </ol>
Chain jumping	<ol style="list-style-type: none"> <li>1. Sprockets worn.</li> <li>2. Chain worn.</li> </ol>	<ol style="list-style-type: none"> <li>1. Have sprockets replaced.</li> <li>2. Have chain replaced.</li> </ol>
Belt Slipping	<ol style="list-style-type: none"> <li>1. Belt is loose.</li> </ol>	<ol style="list-style-type: none"> <li>1. Replace belt.</li> </ol>
Roller case will not lower	<ol style="list-style-type: none"> <li>1. Thickness gauge setting restricts roller case.</li> </ol>	<ol style="list-style-type: none"> <li>1. Reset thickness gauge.</li> </ol>
Excessive dust in air	<ol style="list-style-type: none"> <li>1. Leaking bag or hose connection.</li> </ol>	<ol style="list-style-type: none"> <li>1. Check connections or replace collection bag.</li> </ol>
Fan very loud	<ol style="list-style-type: none"> <li>1. Debris caught in fan.</li> <li>2. Fan is loose.</li> </ol>	<ol style="list-style-type: none"> <li>1. Remove debris.</li> <li>2. Tighten hardware on fan.</li> </ol>



**Follow all safety precautions whenever diagnosing or servicing the tool. Disconnect power supply before service.**

## Troubleshooting

<b>Problem</b>	<b>Possible Causes</b>	<b>Likely Solutions</b>
Motor overheats	1. Motor overloaded. 2. Motor not cooling right.	1. Reduce depth of cut 2. Clean sawdust from Planer.
Circuit breaker or fuse keeps tripping	1. Motor overloaded. 2. Wrong circuit breaker or fuse. 3. Dull blades.	1. Reduce depth of cut. 2. Use correct circuit breaker or fuse. 3. Replace blades.



**Follow all safety precautions whenever diagnosing or servicing the tool. Disconnect power supply before service.**

### PLEASE READ THE FOLLOWING CAREFULLY

THE MANUFACTURER AND/OR DISTRIBUTOR HAS PROVIDED THE PARTS LIST AND ASSEMBLY DIAGRAM IN THIS MANUAL AS A REFERENCE TOOL ONLY. NEITHER THE MANUFACTURER OR DISTRIBUTOR MAKES ANY REPRESENTATION OR WARRANTY OF ANY KIND TO THE BUYER THAT HE OR SHE IS QUALIFIED TO MAKE ANY REPAIRS TO THE PRODUCT, OR THAT HE OR SHE IS QUALIFIED TO REPLACE ANY PARTS OF THE PRODUCT. IN FACT, THE MANUFACTURER AND/OR DISTRIBUTOR EXPRESSLY STATES THAT ALL REPAIRS AND PARTS REPLACEMENTS SHOULD BE UNDERTAKEN BY CERTIFIED AND LICENSED TECHNICIANS, AND NOT BY THE BUYER. THE BUYER ASSUMES ALL RISK AND LIABILITY ARISING OUT OF HIS OR HER REPAIRS TO THE ORIGINAL PRODUCT OR REPLACEMENT PARTS THERETO, OR ARISING OUT OF HIS OR HER INSTALLATION OF REPLACEMENT PARTS THERETO.

**PARTS LIST**

Part	Description	Qty
1	Head Screw (20mm)	1
2	Flat Washer (6mm)	1
4	Elevating Handle	1
5	Label	1
6	Handle Cap	1
7	Handle Bolt	1
8	Handle Base	1
9	Cap	1
10	Upper Cover	1
11	Clevis Pin	4
12	Bushing	4
13	Roller	2
15	Head Screw (16mm)	4
16	Grip	2
17	Screw (6mm)	4
18	Air Guide	1
19	Head Screw (10mm)	2
20	Dust Guard	1
21	Screw (5mm)	3
22	Head Screw (10mm)	3
23	Dust Chute Panel	1
24	Head Screw (10mm)	2
25	Fan Cover	1
26	Head Screw (25mm)	1
27	Dust Chute	1
27.1	Hex Nut (10mm)	1
27.2	Collar	1
27.3	Pin	1
27.4	Clamp	1
27.5	Eye Bolt (50mm)	1
27.6	Filter Bag	1
27.7	Pin	3
27.8	Connector	3
44	Hex Nut (1.25mm)	1
45	Spring Washer (8mm)	1
46	Cam (Left)	1
47	Retainer Ring	2
48	Spring Pin (12mm)	2
49	Lock Lever	1
50	Spring	1
51	Lock Lever Cap	1

**PARTS LIST**

Part	Description	Qty
52	Head Screw (12mm)	1
53	Flat Washer (6mm)	1
54	Fan	1
55	Fan Shaft	1
56	Bearing	2
57	Spacer	1
58	Deflector Cover	1
59	Set Screw (6mm)	1
60	Fan Pulley	1
61	Belt	1
62	Rod	4
63	Spring	4
64	Pad	4
65	Cam (Right)	1
66	Spring Washer	1
67	Hex Nut (1.25mm)	1
68	Bushing	1
69	Guide Rod	1
70	Retainer Ring	1
71	Head Screw (10mm)	2
72	Bushing	1
73	Bracket	1
74	Handle Grip	1
75	Handle	1
76	Retainer Ring	3
77	Set Screw (6mm)	1
78	Guide Bracket	1
79	Set Screw (6mm)	1
80	Sliding Bar	1
81	Head Screw (12mm)	2
82	Bearing	1
83	Bearing Retainer	1
84	Spindle Washer	1
85	Sprocket	1
86	Washer (4mm)	1
87	Socket Head Screw (10mm)	1
88	Spring	2
88A	Spindle Washer	2
89	Head Screw (30mm)	2
90	Guide Rod	1
91	Gear	2
92	Transmission Seat	1
93	Bearing	1
94	Gear	1
95	Spring Holder	4

**PARTS LIST**

Part	Description	Qty
96	Spring	3
96A	Spring	1
97	Steel Ball	4
98	Bushing	4
99	Transmission Collar	1
100	Head Screw (16mm)	2
101	Holder	1
102	Retainer Ring	1
103	Chain	1
104	Sprocket	1
105	Head Screw (20mm)	1
106	Flat Washer	1
107	Spring	1
108	Tension Wheel Assembly	1
109	Spacer	1
110	Head Screw (30mm)	2
111	Head Screw (35mm)	4
112	Outside Cover	1
113	Bearing	1
114	Shaft	1
114a	Key (20mm)	1
115	Gear (Intermediate)	1
116	Gear (Large)	1
117	Spacer	2
118	Inside Cover	1
119	Pinion Gear	1
120	6202 Bearing	1
122	Gear (Small)	1
123	Bushing	5
124	Spacer Undercut	4
125	Nut	1
126	Set Screw (6mm)	1
127	Elevating Nut (L)	1
128	Head Screw (10mm)	2
129	Set Plate	1
130	Head Screw (14mm)	2
131	Head Screw (10mm)	1
132	Cable Clamp	1
133	Head Screw (10mm)	2
134	Belt Guard	1



**PARTS LIST**

Part	Description	Qty
135	Screw	1
136	Elevating Nut (R)	1
137	Hex Screw (16mm)	4
138	Hex Nut (8mm)	4
139	Tap Screw (8mm)	2
140	Tooth Washer	2
141	Cover	1
142	Head Screw (10mm)	2
143	Pointer Cover	1
144	Head Screw (14mm)	1
145	Spring	1
146	Pointer	1
147	Bushing	2
148	Head Screw (8mm)	2
149	Pointer Housing	1
150	Nut	1
151	Roller Case	1
151.1	Motor	1
151.2	Gasket	1
151.3	Cap	1
151.4	Head Screw (6mm)	2
151.5	Flat Washer	2
151.6	Pointer	1
152	Steel Ball	1
153	Retaining Plate	1
154	Tap Screw (6mm)	2
155	Magnet	4
156	Magnet Seat	4
157	Head Screw (10mm)	4
158	Hex Nut (5mm)	1
159	Step Rod	1
160	Hex Nut (8mm)	1
161	Head Screw (16mm)	1
162	Flat Washer	1
163	Head Screw (25mm)	1
164	Press Line Plate	1
165	Head Screw (10mm)	1
166	Flat Washer	1
167	Head Screw (10mm)	1
168	Cutter Head	1
169	Key (12mm)	1
170	Blade	2

**PARTS LIST**

Part	Description	Qty
171	Blade Lock Bar	2
172	Head Screw (16mm)	12
173	Cutter Head Pin	4
174	Spring	4
175	Bearing Retainer	1
176	Bearing	1
177	Bearing Cover	1
178	Head Screw (12mm)	3
179	Spring	1
180	Cutter Head Lock	1
181	Lock Spacer	1
182	Head Screw (10mm)	1
184	Cutter Head Pulley	1
185	Hex Nut	1
186	Belt	1
187	Set Screw (6mm)	1
188	Cutter Head Extend Pulley	1
189	Motor Pulley	1
190	Spring (Outfeed)	2
191	Roller	2
192	Spring (Infeed)	2
193	Retainer Ring	2
194	Sprocket	2
195	Bearing Block	4
196	Retainer	4
197	Head Screw (10mm)	8
198	Side Cover (L)	1
200	Thread Forming Screw (30mm)	4
201	Line Knob	2
203	Hex Wrench	1
204	Magnet	2
205	Plate	1
206	Guide	2
207	Head Screw (10mm)	8
208	Retainer Ring	2
209	Column	2
210	Column	2
211	Elevating Screw	2
212	Base	1
213	Hex Nut (1.75mm)	4
214	Head Screw (20mm)	4
215	Hex Nut	4

**PARTS LIST**

Part	Description	Qty
220	Head Screw (6mm)	8
220.1	Flat Washer	8
221	Table Support	2
222	Extension Table	2
223	Roller Plate (Right)	2
224	Idler Bracket	1
225	Flat Washer	2
226	Head Screw (12mm)	2
227	Sprocket	1
228	Spacer	1
229	Flat Washer	1
230	Head Screw (20mm)	1
231	Chain	1
232	Head Screw (10mm)	4
233	Bearing	2
234	Bearing Retainer	2
235	Spindle Washer	2
236	Sprocket	2
237	Washer	2
238	Head Screw (12mm)	2
239	Hex Nut	4
240	Adjust Screw	4
241	Retainer Ring	1
242	Step Bracket	1
243	Step	1
244	Shaft	1
245	Head Screw (16mm)	2
246	Steel Ball	1
247	Spring	1
248	Set Screw (6mm)	1
249	Spring Pin	1
250	Side Cover (R)	1
251	Height Adjustment Knob	1
252	Spring Washer	4

# ASSEMBLY DIAGRAM

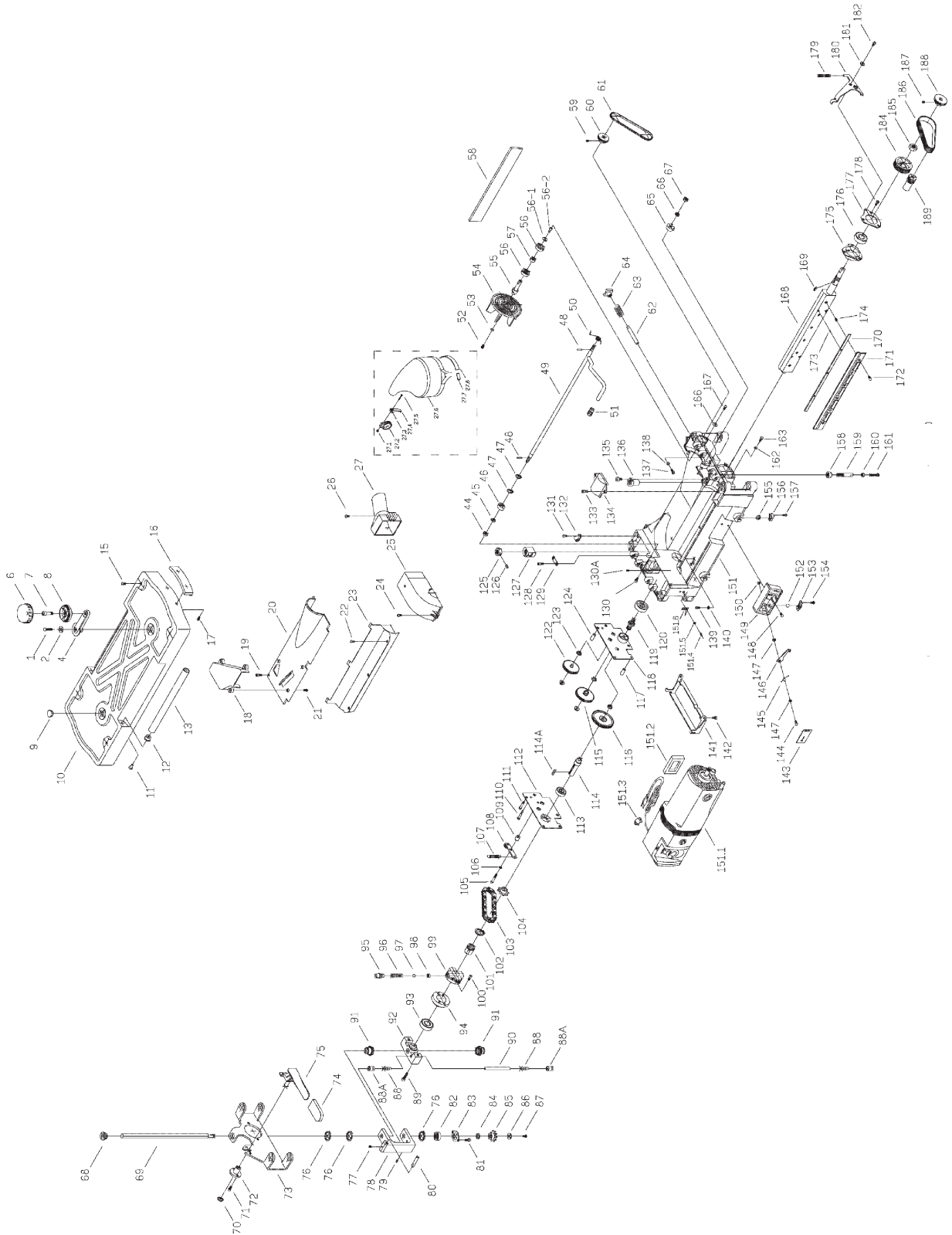

**Diagram continued next page**

# ASSEMBLY DIAGRAM, CONTINUED

## Base of Planer

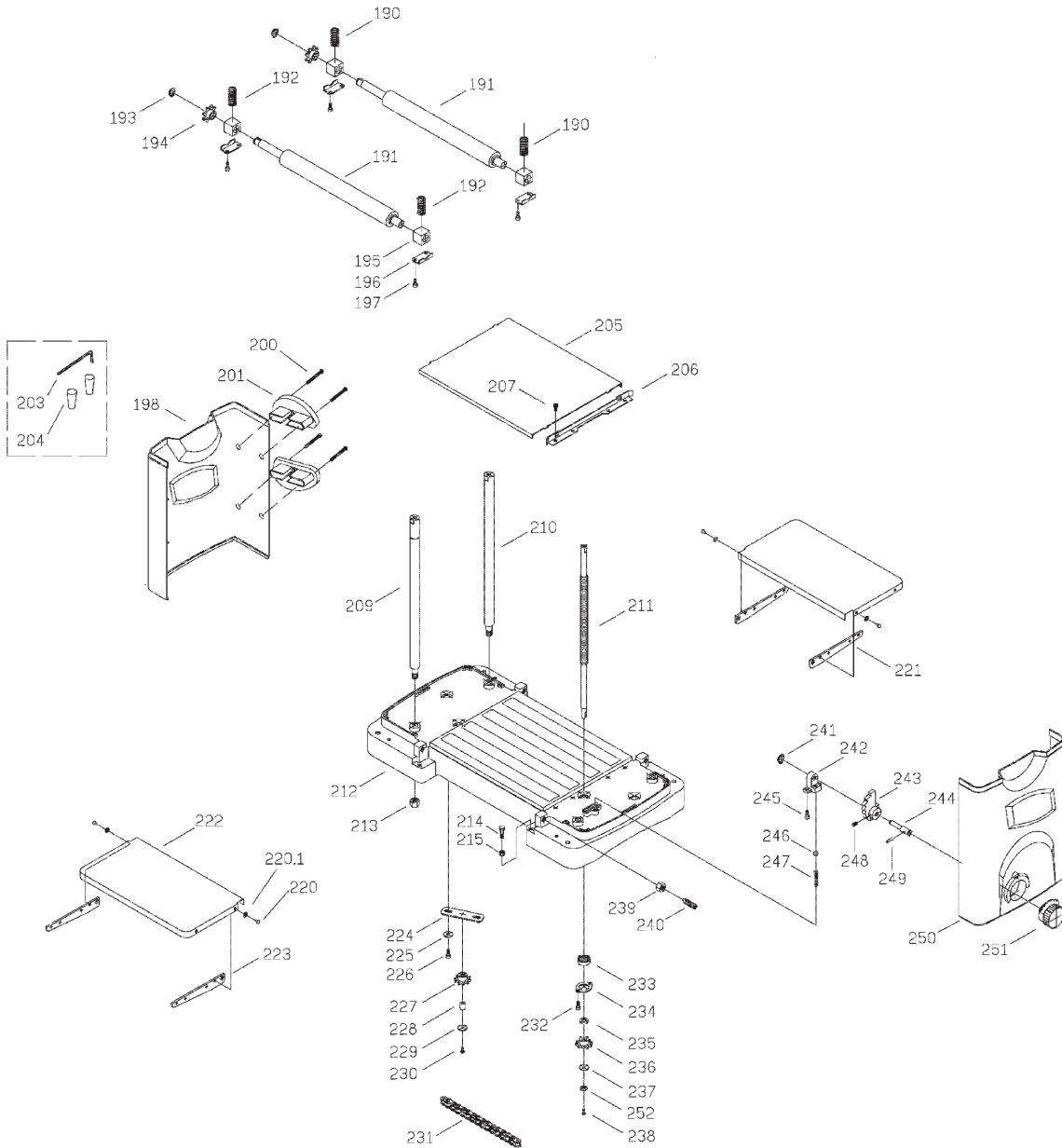

---

## LIMITED 90 DAY WARRANTY

---

Harbor Freight Tools Co. makes every effort to assure that its products meet high quality and durability standards, and warrants to the original purchaser that this product is free from defects in materials and workmanship for the period of 90 days from the date of purchase. This warranty does not apply to damage due directly or indirectly, to misuse, abuse, negligence or accidents, repairs or alterations outside our facilities, criminal activity, improper installation, normal wear and tear, or to lack of maintenance. We shall in no event be liable for death, injuries to persons or property, or for incidental, contingent, special or consequential damages arising from the use of our product. Some states do not allow the exclusion or limitation of incidental or consequential damages, so the above limitation of exclusion may not apply to you. THIS WARRANTY IS EXPRESSLY IN LIEU OF ALL OTHER WARRANTIES, EXPRESS OR IMPLIED, INCLUDING THE WARRANTIES OF MERCHANTABILITY AND FITNESS.

To take advantage of this warranty, the product or part must be returned to us with transportation charges prepaid. Proof of purchase date and an explanation of the complaint must accompany the merchandise. If our inspection verifies the defect, we will either repair or replace the product at our election or we may elect to refund the purchase price if we cannot readily and quickly provide you with a replacement. We will return repaired products at our expense, but if we determine there is no defect, or that the defect resulted from causes not within the scope of our warranty, then you must bear the cost of returning the product.

This warranty gives you specific legal rights and you may also have other rights which vary from state to state.

**3491 Mission Oaks Blvd. • PO Box 6009 • Camarillo, CA 93011 • (800) 444-3353**

**Record Product's Serial Number Here:** \_\_\_\_\_

**Note:** If product has no serial number, record month and year of purchase instead.

**Note:** Some parts are listed and shown for illustration purposes only, and are not available individually as replacement parts.